

QUICK-DISCONNECTS

TMEDN : Nylon

■ FULLY INSULATED
FEMALE DISCONNECTS

■ 250 SERIES

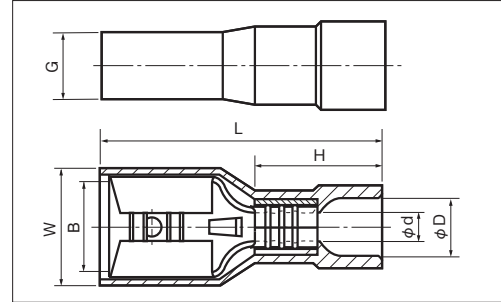

RoHS 10
See page 2

PART NUMBER	DIMENSIONS mm							MATING TAB THICKNESS mm	WIRE RANGE		TOOL No. HAND TOOL No.		STD COLOR	STD QTY/BOX
	B	W	L	φd	φD	G	H		STRANDED mm ²	AWG	TOOL BODY No.	DIES No.		
TMEDN 630809-FA ○	6.8	9.0	21.0	1.7	4.1	4.9	9.5	0.8	0.75~1.25	18-16	NH 11 NH 32 NA 10 NA 3	N10 11 N3 11	RED TRANSLUCENT	1,000 (100×10)
TMEDN 630820-FA ○	6.8	9.0	21.0	2.4	4.5	5.2	9.5	0.8	2.0	14	NH 12 NH 32 NA 10 NA 3	N10 12 N3 12	BLUE TRANSLUCENT	1,000 (100×10)

Mate with TMEDN 630809MA and TMEDN 630820MA

■ FULLY INSULATED
MALE DISCONNECTS

■ 250 SERIES

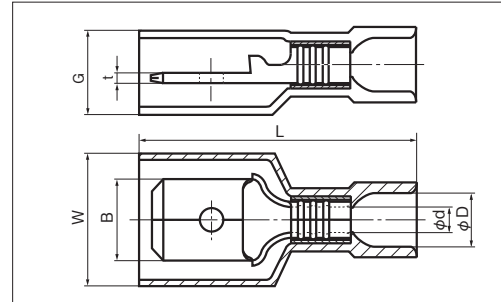

RoHS 10
See page 2

PART NUMBER	DIMENSIONS mm							MATING TAB THICKNESS mm	WIRE RANGE		TOOL No. HAND TOOL No.		STD COLOR	STD QTY/BOX
	B	W	t	L	φd	φD	G		H	STRANDED mm ²	AWG	TOOL BODY No.		
TMEDN 630809-MA ○	6.3	10.3	0.8	22.0	1.8	4.1	6.4	10.0	0.75~1.25	18-16	NH 11 NH 32 NA 10 NA 3	N10 11 N3 11	RED TRANSLUCENT	500 (100×5)
TMEDN 630820-MA ○	6.3	10.3	0.8	22.0	2.5	4.5	6.4	10.0	2.0	14	NH 12 NH 32 NA 10 NA 3	N10 12 N3 12	BLUE TRANSLUCENT	500 (100×5)

It is not appropriate to mate with ICTDN 630809FA and ICTDN 630820FA

NOTE 1) ○ : UL/CSA

2) Refer to page 71 for UL/CSA, proper strip length of wire and Nylon insulated products.